



Modular Cooking Range Line 700XP 3 Drawer Refrigerated Base (60Hz)

ITEM # _____

MODEL # _____

NAME # _____

SIS # _____

AIA # _____



371372 (E7TTAPCOMKN)

Refrigerated base with 3 drawers, +10-2°C - R290 (Brazil, Saudi Arabia)

Short Form Specification

Item No. _____

Built-in refrigerator compressor unit. Operating temperature range from -2°C to 10°C. To be installed below 700XP top units. To be delivered with 50 mm height adjustable feet. Exterior panels in stainless steel with Scotch Brite finish. One piece pressed work top in 1.5 mm thick stainless steel. Right-angled side edges to allow flush-fitting junction between units.

Main Features

- Unit can be easily installed below other 700 line top models.
- Adjustable temperature range from -2 °C to +10 °C to suit meat, fish and dairy storage requirements.
- Anti-tilt runners accept GN 1/1 containers.
- Forced air circulation for rapid cooling and an even temperature distribution.
- Right angled side edges eliminate gaps and possible dirt traps between units.
- Designed for modular installation into the cooking block.

Construction

- Constructed in Stainless steel with Scotch Brite finish to meet the highest hygiene standards.
- Built-in compressor to suit operating conditions.
- Access to all components from the front.
- Unit delivered with 150 mm height adjustable feet in Stainless steel. Feet can be extended up to 250 mm.

Sustainability



- CFC and HCFC free (highly ecological refrigerant type: R290).

Optional Accessories

- Flanged feet kit PNC 206136
- Frontal kicking strip for concrete installation, 1600mm PNC 206152
- Single burner radiant plate for pan support PNC 206170
- Frontal kicking strip, 1600mm (not for refr-freezer base) PNC 206179
- Kit 4 feet for concrete installation (not for 900 line free standing grill) PNC 206210
- 2 panels for service duct for single "top on base" installation PNC 206248
- Pair of side kicking strips PNC 206249
- Pair of side kicking strips for concrete installation PNC 206265
- 2 drawers for refrigerated base PNC 206351
- Base support for feet or wheels - 1600mm (700/900) PNC 206369
- Kit 6 wheels - 3 swivelling with brake PNC 206432
- 2 side covering panels for free standing appliances PNC 216000

APPROVAL: _____



Experience the Excellence
www.electroluxprofessional.com

Front

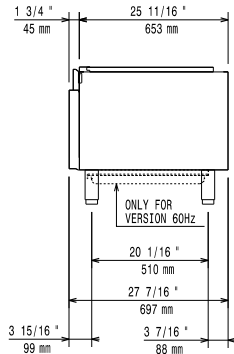

Side

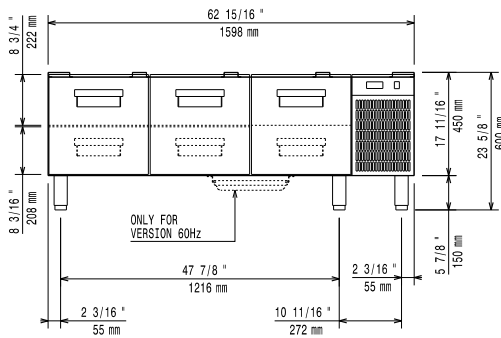

D = Drain
 EI = Electrical inlet (power)

Top

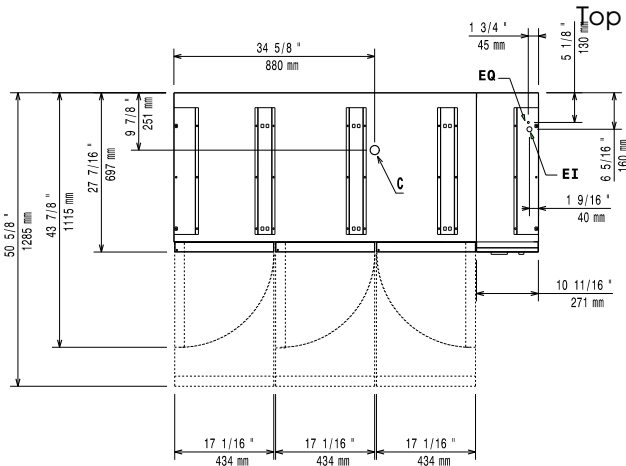

Electric

Supply voltage:	371372 (E7TTAPCOMKN)	220-230 V/1N ph/60 Hz
Electrical power max.:		0.4 kW
Total Watts:		0.4 kW

Key Information:

Gross capacity:	240 lt
External dimensions, Width:	1600 mm
External dimensions, Depth:	700 mm
External dimensions, Height:	600 mm
Net weight:	110 kg
Shipping weight:	130 kg
Shipping height:	820 mm
Shipping width:	800 mm
Shipping depth:	1700 mm
Shipping volume:	1.12 m ³

Sustainability

Refrigerant type:	R290
Refrigerant weight:	85 g